

MODEL	2WIRE TRANSMITTER (SPECIAL)
MR-2WRT-S	



본 제품은 주변온도 (상온)를 측정하여 전송하기 위한 제품입니다. 전원 및 신호선 연결시 극성에 유의하여 주시기 바랍니다.

■ GENERAL SPECIFICATION

Construction : wall mount(tape)
 Housing material : plastic (ivory)
 Wiring : screw terminals on P.C.B (M2.5)
 Isolation : none isolation
 Weight : about 50g

■ PERFORMANCE

Insulation resistance : greater than 100Mohm with 500V/DC
 Dielectric strength : 1500VAC at 1Min (input, output/housing)
 Accuracy : $\pm 0.2\%$ Max.
 Response time : 0.5 Sec. /0-90%

■ INSTALLATION

Operating temperature : -5 ~ 55°C
 Operating humidity : 0 ~ 90 %RH
 Mounting : tape mount
 Power input : DC 18-28V (Ripple 5%p-p Max.)

■ INPUT SIGNAL

RTD SENSOR : PT100ohm (138.50 / 100 °C)

■ OUTPUT SIGNAL

DC CURRENT : 4 - 20 mA
 Min. Span : 4mA
 Load resistance : 650ohm at 20mA/24v

■ MODEL & SPECIFICATION CODE

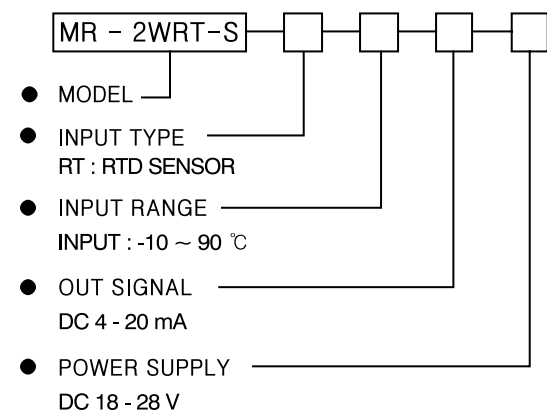

2WIRE TRANSMITTER (SPECIAL)

MODEL
MR-2WRT-S

■ DIMENSION

